

# SPECIFICATIONS

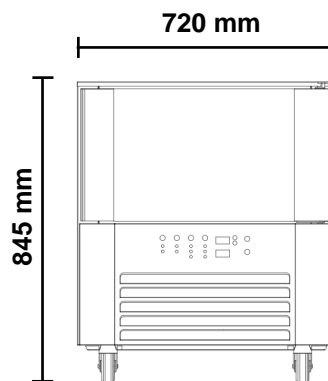

## CBCF 10 U/C

Blast Chiller/Freezer Under Counter



### Options:

- Extra Shelves
- Extra Slides
- ST/ST Back
- Helicoil Cable
- HFO Blast Chiller

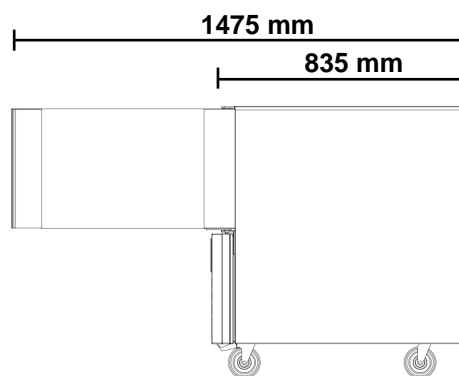

### SPECIFICATIONS

<b>Refrigeration system:</b>	Electronic controlled, self-contained, bottom mounted, refrigeration unit
<b>Refrigerant:</b>	R404a / 800g
<b>Nominal capacity:</b>	1679 Watts @ -5°C SST
<b>Cabinet internal volume:</b>	10 kilogram capacity
<b>Insulation:</b>	60mm thick, high density 0 ODP injected polyurethane insulation
<b>Cabinet temperature range:</b>	+90°C to +3°C in 90mins & +90°C to -18°C in 240 mins (43°C ambient)
<b>Drainage:</b>	Waste Heat Vaporiser located in service comp. (no plumbing required)
<b>Electrical:</b>	230 Volts a.c. 50 Hz, 3.9 Amps
<b>kWh/24 hr :</b>	N/A
<b>Internal door opening size:</b>	1 door opening: Accepts full 1/1 GN pans (325mm wide x 530mm deep)
<b>Doors:</b>	Solid stainless steel, self-closing door
<b>Shelves:</b>	3 x adjustable tray slides per door
<b>Weight:</b>	85 kg

### CABINET DIMENSIONS

	External	Internal
<b>Width:</b>	720mm	600mm
<b>Depth:</b>	835mm	615mm
<b>Height:</b>	745mm*	320mm
<b>Floor area:</b>	0.60m <sup>2</sup>	

\* Height excludes castors or legs